

Re-inforced Window Profile.

- 1). Locate the Sash Jammer onto section making sure that the window can still open & close without contact with the Sash Jammer Body.
- 2). Drill 3mm pilot holes into the section using the Sash Jammer as a Jig.
- 3). If after drilling through 2 walls or webs of PVC-u the 3mm drill encounters section re-inforcing, steel or aluminium, fixing the Sash Jammer to this re-inforcing will create a solid fix. Either drill through re-inforcing section or use a self tapping screw to penetrate.
- 4). To obtain a solid fix use re-inforcing retaining screws. Once fitted, select correct size of Button and position underneath the lever in the hole provided. A slight compression should be achieved but not so that the PVC-u section will be marked.

NOTE: If using a 3mm drill use 3.9mm or 4.3mm diameter screws. Length of screw is determined by the position of the re-inforcing, this will vary from section to section.

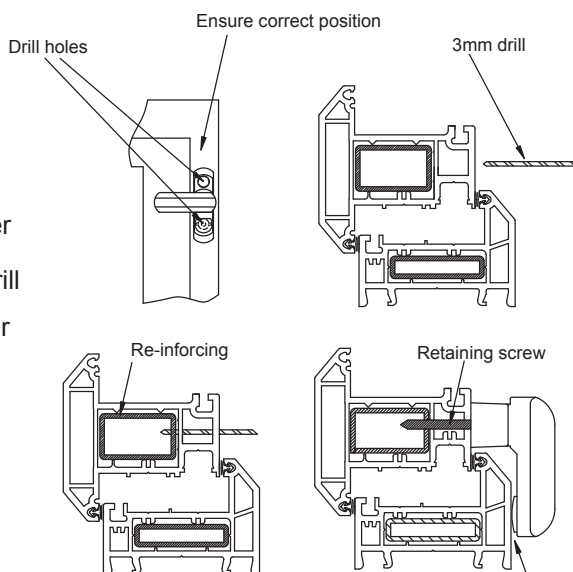

Window Profile - No Re-inforcement.

- 5). If after drilling through 2 walls or webs of PVC-u, NO re-inforcing is encountered, the following fix is required. Where the 3mm drill holes are located increase the hole sizes to 9mm using a 9mm drill also drilling through any internal webs close to the surface.
- 6). Insert the Jack Nut within the 9mm hole, tap with a hammer if tight or increase hole size. The Jack Nut should be a relatively tight fit.
- 7). Using M5 Machine Thread screws of at least 35mm, place the Sash Jammer over the Jack Nuts and insert the screws through the Sash Jammer and into the Jack Nuts.
- 8). Tighten with a high-torque battery or electric screw driver until the Sash Jammer is fixed solid. The Jack Nuts will act as a rawl type product and fix themselves underneath the PVC-u section creating a solid fixture. Once fitted, select correct size of Button and position underneath the lever in the hole provided. A slight compression should be achieved but not so that the PVC-u section will be marked.

NOTE: Please ensure that the correct screw driver bit is used for the type of screw used. The screw heads will strip otherwise. If this does occur before a solid fix is made, take the existing screw out and use a new one.

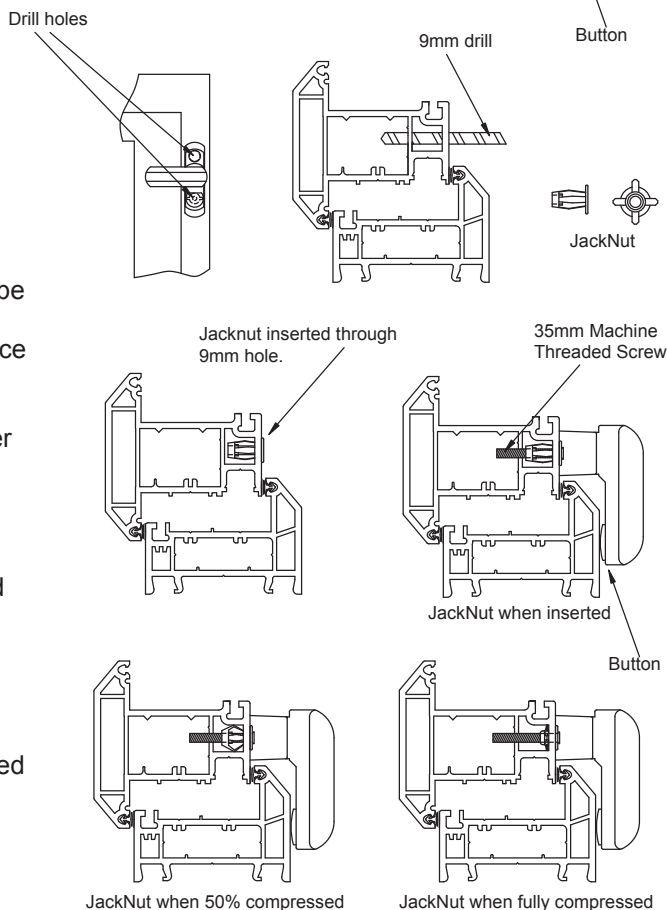

www.euro-secure.com

Manual Page Reference :-

S3 - 1-2

FD1

Issue	Description	Drawn	Chkd	Date
2	Address Details Amended.	WMH	WH	08.09.08



Suitability of Sash Jammers.

- 1). On internally beaded window section. I.e where the glass is fitted from the inside:- The Sash Jammer will fit all sections.
- 2). On externally beaded window section. I.e where the glass is fitted from the outside:- The fitter should check that the Sash Jammer may be located onto the section **without** any fixings entering the glazing chamber where the glass is situated.

Height between Sash & Frame.

- 3). Check the height between the Sash and Frame to ensure that it will accomodate a Sash Jammer.

Heights achievable with standard pack:-

- * Minimum height accomodated - 16mm (Using 5mm Button).
- * Maximum height accomodated - 20mm (Using 1mm Button).

Heights achievable with add-on products:-

- * Minimum height accomodated - 12mm (Using special order 9mm Button).
- * Maximum height accomodated - Unlimited (packers can be used to increase maximum height).

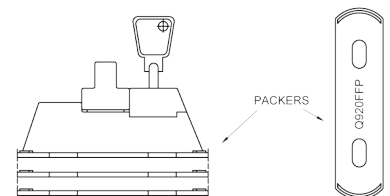
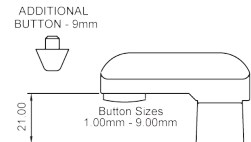

Open-Out windows.

- 4). Fit Sash Jammer to the **opening part** of the window. (Sash)

Open-In windows.

- 5). Fit Sash Jammer to the **frame part** of the window. (Frame)

Where to fit the Sash Jammers (Windows).

Locking Side:- The Sash Jammer is a product that increases security on windows already in situ and compliments locking systems already in place.

Cockspur:-

- Upto 900mm Sash Rebate - 1 Cockspur handle located centrally = 2 Sash Jammers
- 2 Cockspur handles located at each end = 2 Sash Jammers

- Over 900mm Sash Rebate - 1Cockspur handle located centrally = 4 Sash Jammers
- 2 Cockspur handles located at each end = 3 Sash Jammers (One in the center).

Roller / Mushroom Locking Espag with No Shootbolt:-

- Upto 900mm Sash Rebate - 2 Sash Jammers inline with the keeps to support the locking system.

- Over 900mm Sash Rebate - 3 Sash Jammers - the espag will probably have 3 lockpoints, 1 Sash Jammer to support each lockpoint.

Shootbolt Espag:-

Where to fit the Sash Jammers (Doors).

Centre Latch, Roller / Mushroom Cams:-

4 Sash Jammers placed evenly along the length of door.

Centre Latch, Centre Deadbolt, Roller / Mushroom Cams:-

2 Sash Jammers placed 150mm from top and bottom.

Centre Latch, Centre Deadbolt, Top & Bottom Dead or Hook Bolts:-

No Sash Jammers needed on such a locking system.

French Doors (Double Openers):-

Main Door - As above

Slave Door - 4 Sash Jammers placed evenly along the length of door.

NOTE:- Sash jammers may be difficult to position on French Doors, but they do need securing as they are often very weak.

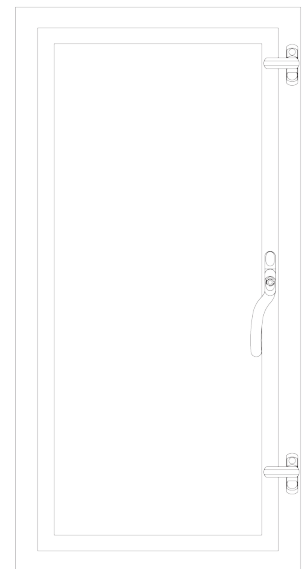

www.euro-secure.com

01429 874580

Manual Page Reference :- S3 - 1-2

FD2

Issue	Description	Drawn	Chkd	Date
2	Address Details Amended.	WMH	AW	08.09.08